

HM8014

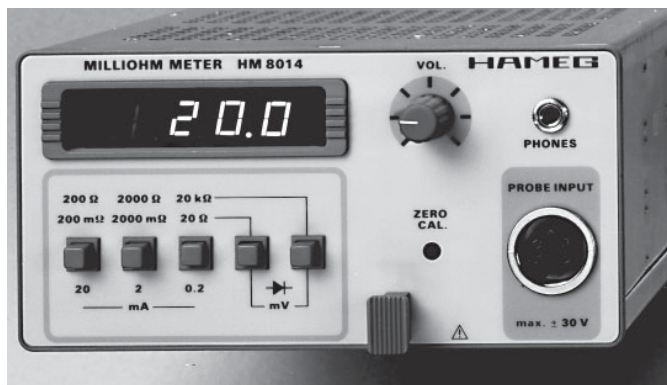

General information regarding the CE marking

HAMEG instruments fulfill the regulations of the EMC directive. The conformity test made by HAMEG is based on the actual generic- and product standards. In cases where different limit values are applicable, HAMEG applies the severer standard. For emission the limits for residential, commercial and light industry are applied. Regarding the immunity (susceptibility) the limits for industrial environment have been used.

The measuring- and data lines of the instrument have much influence on emission and immunity and therefore on meeting the acceptance limits. For different applications the lines and/or cables used may be different. For measurement operation the following hints and conditions regarding emission and immunity should be observed:

1. Data cables

For the connection between instruments resp. their interfaces and external devices, (computer, printer etc.) sufficiently screened cables must be used. Without a special instruction in the manual for a reduced cable length, the maximum cable length of a dataline must be less than 3 meters long. If an interface has several connectors only one connector must have a connection to a cable.

Basically interconnections must have a double screening. For IEEE-bus purposes the double screened cables HZ72S and HZ72L from HAMEG are suitable.

2. Signal cables

Basically test leads for signal interconnection between test point and instrument should be as short as possible. Without instruction in the manual for a shorter length, signal lines must be less than 3 meters long.

Signal lines must be screened (coaxial cable - RG58/U). A proper ground connection is required. In combination with signal generators double screened cables (RG223/U, RG214/U) must be used.

3. Influence on measuring instruments.

Under the presence of strong high frequency electric or magnetic fields, even with careful setup of the measuring equipment an influence of such signals is unavoidable.

This will not cause damage or put the instrument out of operation. Small deviations of the measuring value (reading) exceeding the instruments specifications may result from such conditions in individual cases.

KONFORMITÄTSERKLÄRUNG
DECLARATION OF CONFORMITY
DECLARATION DE CONFORMITE



HAMEG[®]
Instruments

Name und Adresse des Herstellers
Manufacturer's name and address
Nom et adresse du fabricant

HAMEG GmbH
Kelsterbacherstraße 15-19
D - 60528 Frankfurt

HAMEG S.a.r.l.
5, av de la République
F - 94800 Villejuif

Die HAMEG GmbH / HAMEG S.a.r.l. bescheinigt die Konformität für das Produkt
The HAMEG GmbH / HAMEG S.a.r.l. herewith declares conformity of the product
HAMEG GmbH / HAMEG S.a.r.l. déclare la conformité du produit

Bezeichnung / Product name / Designation: L-C Meter / LC-METRE / Medidor LC

Typ / Type / Type: **HM8014**

mit / with / avec: **HM8001-2**

Optionen / Options / Options: -

mit den folgenden Bestimmungen / with applicable regulations / avec les directives suivantes

EMV Richtlinie 89/336/EWG ergänzt durch 91/263/EWG, 92/31/EWG
EMC Directive 89/336/EEC amended by 91/263/EWG, 92/31/EEC
Directive EMC 89/336/CEE amendée par 91/263/EWG, 92/31/CEE

Niederspannungsrichtlinie 73/23/EWG ergänzt durch 93/68/EWG
Low-Voltage Equipment Directive 73/23/EEC amended by 93/68/EEC
Directive des équipements basse tension 73/23/CEE amendée par 93/68/CEE

Angewendete harmonisierte Normen / Harmonized standards applied / Normes harmonisées utilisées

Sicherheit / Safety / Sécurité

EN 61010-1: 1993 / IEC (CEI) 1010-1: 1990 A 1: 1992 / VDE 0411: 1994
Überspannungskategorie / Overvoltage category / Catégorie de surtension: II
Verschmutzungsgrad / Degree of pollution / Degré de pollution: 2

Elektromagnetische Verträglichkeit / Electromagnetic compatibility / Compatibilité électromagnétique

EN 50082-2: 1995 / VDE 0839 T82-2
ENV 50140: 1993 / IEC (CEI) 1004-4-3: 1995 / VDE 0847 T3
ENV 50141: 1993 / IEC (CEI) 1000-4-6 / VDE 0843 / 6
EN 61000-4-2: 1995 / IEC (CEI) 1000-4-2: 1995 / VDE 0847 T4-2: Prüfschärfe / Level / Niveau = 2

EN 61000-4-4: 1995 / IEC (CEI) 1000-4-4: 1995 / VDE 0847 T4-4: Prüfschärfe / Level / Niveau = 3

EN 50081-1: 1992 / EN 55011: 1991 / CISPR11: 1991 / VDE0875 T11: 1992

Gruppe / group / groupe = 1, Klasse / Class / Classe = B

Datum /Date /Date

14.12.1995

Unterschrift / Signature / Signatur

E. Baumgartner
Technical Manager
Directeur Technique

Specification:

(Reference Temperature: 23°C ± 1°C)

Operating Modes:

Milliohm Measurement

Diode Testing

Milliohm Measurement:

Range: 200 mΩ - 20 kΩ

subdivided in 6 decade steps

Resolution: 100 μΩ

Accuracy: (4-point measurement)

Range 200 mΩ to 20 Ω: 0.25% o.v.³⁾ ± 2 digit

Range 200 Ω to 20 kΩ: 0.25% o.v.³⁾ ± 1 digit

Probe tip voltage and measuring current:

Range	Voltage ¹⁾	Current	Voltage ²⁾
200 mΩ	6 mV	20 mA	4 mV
2 Ω	6 mV	2 mA	4 mV
20 Ω	6 mV	0.2 mA	4 mV
200 Ω	300 mV	1 mA	200 mV
2000 Ω	300 mV	100 μA	200 mV
20 kΩ	300 mV	10 μA	200 mV

Max. admissible input voltage: ± 30V

Diode Testing:

Voltage range: 1999 mV

Accuracy: 0.25% o.v.³⁾ ± 1 digit

Probe tip voltage and measuring current:

Range	Voltage ¹⁾	Current	Voltage ²⁾
1999 mV	3V	20 mA	2V
1999 mV	3V	2 mA	2V
1999 mV	3V	200 μA	2V

The currents are selectable via pushbuttons for the resistance ranges (200 mΩ, 2 Ω, 20 Ω).

Max. admissible input voltage: ± 30V

Display:

3½ digit 7 segment LED-display

Measuring rate: 3 measurements/sec.

General information:

Audible signal with changing frequency, depending on the measured resistance value.

Built-in loudspeaker

Output power 250 mW

Speaker shut off via phone jack

Zero calibration at front panel

Supply (from HM8001):

+ 5V / 250 mA

+ 7.5V / 60 mA

- 7.5V / 60 mA

(Σ = 3,3W)

Operating conditions:

+ 10°C to + 40°C

max. relative humidity: 80 %

Dimensions (without multipoint connector)

W135, **H**68, **D**228 mm

Weight: approx. 0.65 kg

¹⁾ open circuit probe tip voltage

²⁾ measuring voltage

³⁾ o.v. = of value

Subject to change without notice.

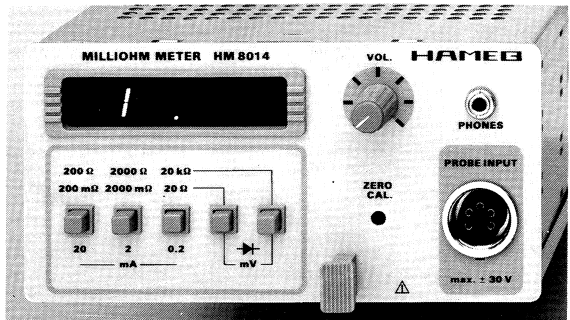

Milliohm Meter HM 8014

- 6 Measuring Ranges
- 200 mΩ to 20 kΩ
- 0.1 mΩ Resolution
- Diode Testing
- Audible Fault Location
- 4-point measurement technic

With a measuring range from 0 Ω to 20 kΩ the **Milliohm Meter HM8014** has been designed for use in production, **quality control**, and **incoming inspections** as well as for laboratory purposes. As a result of its accuracy and measuring rate, it is ideally suited for quick tests of small production series.

The high **resolution of 0.1 mΩ** as well as the low **probe tip voltage of 4 mV**, allow **fast and easy location of short-circuits**, even on completely assembled printed circuit boards. The additional feature of an acoustic signal changing its frequency with varying resistance, enables full concentration on the device under test.

A **diode test function** effectively complements the use of the **HM8014** for service applications. This permits tests of semiconductors with three different constant current values.

Ease-of-operation and a clear front panel layout provide **fast and reliable results** even for the less experienced user.

The HM8014 includes Kelvin probes HZ17.

General information

The operator should not neglect to carefully read the following instructions and those of the mainframe HM8001, to avoid any operating errors and to be fully acquainted with the module when later in use.

After unpacking the module, check for any mechanical damage or loose parts inside. Should there be any transportation damage, inform the supplier immediately and do not put the module into operation.

This plug-in module is primarily intended for use in conjunction with the Mainframe HM8001. When incorporating it into other systems, the module should only be operated with the specified supply voltages.

Safety

Every module is manufactured and tested for use only with the mainframe HM8001 according to IEC 348 Part 1 and 1a (Safety requirements for electronic test and measurement equipment). All case and chassis parts are connected to the safety earth conductor. Corresponding to Safety Class 1 regulations (three-conductor AC power cable). Without an isolating transformer, the instrument's power cable must be plugged into an approved three-contact electrical outlet, which meets International Electrotechnical Commission (IEC) safety standards.

Warning!

Any interruption of the protective conductor inside or outside the instrument or disconnection of the protective earth terminal is likely to make the instrument dangerous. Intentional interruption is prohibited.

The instrument must be disconnected and secured against unintentional operation if there is any suggestion that safe operation is not possible. This may occur:

- if the instrument has visible damage,
- if the instrument has loose parts.
- if the instrument does not function,
- after long storage under unfavourable circumstances (e.g. outdoors or in moist environments),
- after excessive transportation stress (e.g. in poor packaging).

When removing or replacing the metal case, the instrument must be completely disconnected from the mains supply. If any measurement or calibration procedures are unavoidable on the opened-up instrument, these must only be carried out by qualified personnel acquainted with the danger involved.

Symbols As Marked on Equipment



DANGER – High voltage



Protective ground (earth) terminal.



ATTENTION – refer to manual.

Operating conditions

The ambient temperature range during operation should be between +10°C and +40°C and should not exceed –40°C or +70°C during transport or storage. The operational position is optional, however, the ventilation holes on the HM8001 and on the plug-in modules must not be obstructed.

Warranty

Before being shipped, each plug-in module must pass a 24 hour quality control test.

Provided the instrument has not undergone any modifications Hameg warrants that all products of its own manufacture conform to Hameg specifications and are free from defects in material and workmanship when used under normal operating conditions and with the service conditions for which they were furnished.

The obligation of HAMEG hereunder shall expire two (2) years after delivery and is limited to repairing, or at its option, replacing without charge, any such product which in Hameg's sole opinion proves to be defective with the scope of this warranty.

This is Hameg's sole warranty with respect to the products delivered hereunder. No statement, representation, agreement or understanding, oral or written, made by an agent, distributor, representative or employee of, which is not contained in this warranty will be binding upon Hameg, unless made in writing and executed by an authorized Hameg employee. Hameg makes no other warranty of any kind whatsoever, expressed or implied, and all implied warranties of merchantability and fitness for a particular use which exceed the aforesaid obligation are hereby disclaimed by Hameg be liable to buyer, in contract or in tort, for any special, indirect, incidental or consequential damages, expenses, losses or delays however caused.

In case of any complaint, attach a tag to the instrument with a description of the fault observed. Please supply name and department, address and telephone number to ensure rapid service.

The instrument should be returned in its original packaging for maximum protection. We regret that transportation damage due to poor packaging is not covered by this warranty.

Maintenance

The most important characteristics of the instruments should be periodically checked according to the instructions provided in the sections "Operational check" and "Alignment procedure". To obtain the normal operating temperature, the mainframe with inserted module should be turned on at least 60 minutes before starting the test. The specified alignment procedure should be strictly observed.

When removing the case detach mains/line cord and any other connected cables from case of the mainframe HM8001. Remove both screws on rear panel and, holding case firmly in place, pull chassis forward out of case. When later replacing the case, care should be taken to ensure that it properly fits under the edges of the front and rear frames.

After removal of the two screws at the rear of the module, both chassis covers can be lifted. When reclosing the module, care should be taken that the guides engage correctly with the front chassis.

Operation of the module

Provided that all hints given in the operating instructions of the HM8001 Mainframe were followed – especially for the selection of the correct mains voltage – start of operation consists practically of inserting the module into the right or left opening of the mainframe. The following precautions should be observed:

Before exchanging the module, the mainframe must be switched off. A small circle (o) is now revealed on the red power button in the front centre of the mainframe.

If the BNC sockets at the rear panel of the HM8001 unit were in use before, the BNC cables should be disconnected from the basic unit for safety reasons. Slide in the new module until the end position is reached.

Before being locked in place, the cabinet of the instrument is not connected to the protective earth terminal (banana plug above the mainframe multipoint connector). In this case, no test signal must be applied to the input terminals of the module.

Generally, the HM8001 set must be turned on and in full operating condition, before applying any test signal. If a failure of the measuring equipment is detected, no further measurements should be performed. Before switching off the unit or exchanging a module, the instrument must be disconnected from the test circuit.

HM8014 control elements

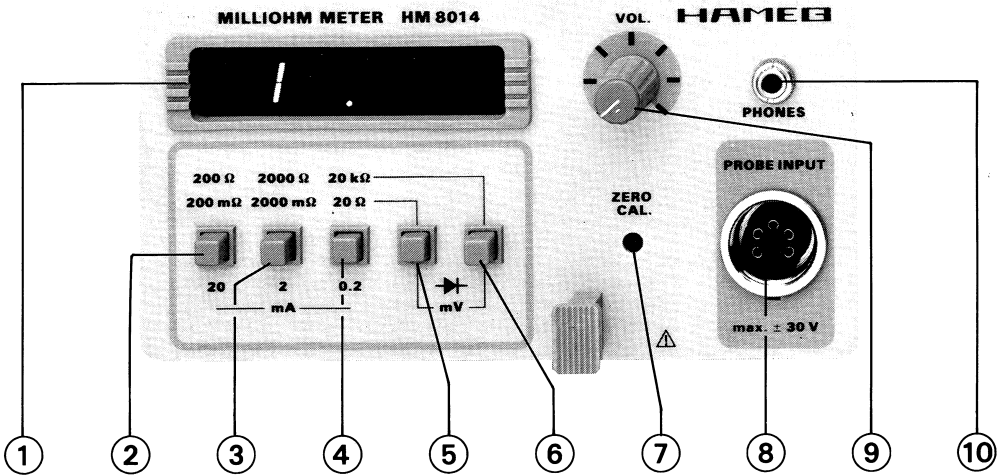

① Display (7-segment LEDs)

3½ digit display for measured value. The values are displayed with correct point position according to the selected measurement range. Overflow indication by "1" in the first position.

② 200 mΩ/200 Ω range selection (pushbutton)

The 200 mΩ or 200 Ω ranges are selected in combination with pushbutton ⑤ or ⑥, respectively.

③ 2000 mΩ/2000 Ω range selection (pushbutton)

The 2000 mΩ or 2000 Ω ranges are selected in combination with pushbutton ⑤ or ⑥, respectively.

④ 20 Ω/20 kΩ range selection (pushbutton)

The 20 Ω or 20 kΩ ranges are selected in combination with pushbutton ⑤ or ⑥, respectively.

③ Range selection (x1) (pushbutton)

Multiply function for pushbutton ② - ④. If pushbutton ⑤ is pressed together with pushbutton ⑥, the integrated diode test function of the HM8014 unit is activated. In this case the set supplies the constant current specified below the corresponding, additionally pressed pushbuttons ② - ④. The voltage drop across the test object is indicated in mV on display ①.

⑥ Range selection (x1000) (pushbutton)

Multiply function for pushbutton ② - ④. If pushbutton ⑤ is pressed together with pushbutton ⑥, the integrated diode test function of the HM8014 unit is activated. In this case the set supplies the constant current specified

below the corresponding, additionally pressed pushbuttons ② - ④. The voltage drop across the test object is indicated in mV on display ①.

⑦ Zero calibration (trimming potentiometer)

Display ① is set to 000.0 with the trimming potentiometer located behind the front panel, the probe tips being short-circuited. This setting should be performed in the 200 mΩ range.

⑧ Probe input (DIN-connector, 5 pole)

Connection for 4-wire cable set HZ17. The maximum admissible input voltage is ±30V.

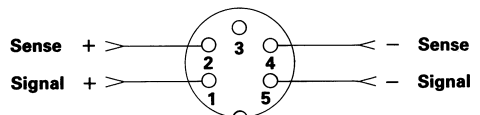

⑨ Volume (adjusting knob)

Volume selector for the integrated loudspeaker or, alternatively, the connected headphones.

⑩ Phones (3.5 mm phone jack)

For connection of external headphones. The integrated loudspeaker is switched off, when headphones are connected.

Operation

Mode selection

The HM8014 milli-ohmmeter permits not only resistance measurement, but also semiconductor testing. The modes are selected via the pushbuttons ⑤ + ⑥. The module is in the resistance measurement mode, when only **one** of the two buttons ⑤ or ⑥ is activated. The semiconductor test function is selected by simultaneously pressing both buttons.

Range selection

The desired measurement range is selected via push-buttons ② – ④ together with ⑤ + ⑥. The combination of pushbutton ⑤ and one of the buttons ② – ④ serves to establish the 200 mΩ, 2000 mΩ or 20 Ω measurement range, whereas the 200 Ω, 2000 Ω and 20 kΩ ranges are selected by pressing pushbutton ⑥ together with ② – ④. The resistance values specified above the pushbuttons are full-scale readings. When the semiconductor test function is switched on, the delivered test currents change from 20 mA to 2 mA or 0.2 mA according to the activated button.

Zero calibration

When very low resistors are measured, the leads resistance of the HZ17 test probes will considerably influence the test result. Therefore every probe should be adapted to the HM8014 unit with the "Zero calibration" trimmer (HM8014 front panel) before starting the measurement. For this purpose, the tips of the HZ17 probes are held together, and the display is set to 000.0 in the 200 mΩ range. Due to the good zero stability of the HM8014 unit, zero calibration will only be required in large time intervals or in case of probe replacement.

Test value application

Low-impedance resistors should preferably be measured by use of the supplied HZ17 probe tip. For fabrication of particular test leads, the 5-pin DIN plug mating with the HM8014 unit can be ordered from HAMEG. Please refer to the notes on two-wire and four-wire measurement technique for further information.

Resistance measurement

During resistance measurement, a DC voltage is applied across the probe tips. The red probe tip has positive potential, whereas the earthy potential of the test voltage is measured across the black tip of the HZ17. Only devices which are not under voltage should be measured, because any voltage present in the test circuit will give an erroneous result. As the test voltage of the HM8014 unit is very low, it is possible to perform resistance measurements on mounted circuit boards. The threshold voltages of semiconductors are not exceeded. Destruction of test objects is almost excluded, the delivered maximum power being very low (see table in the "Principle of Operation" section).

Semiconductor test

The semiconductor test function permits to measure threshold voltages at 3 different switching points. The current values of 0.2 mA, 2 mA or 20 mA respectively,

are selected via the pushbuttons ② – ④. The voltage measured at the test object is directly indicated in mV on the HM8014 display.

Diodes, LEDs and transistors are easily checked or selected with this function.

Overload protection

All measurement ranges of the HM8014 unit are protected against externally applied voltages of up to ±30 V. Application of any higher voltage to the HM8014 input socket will destroy the input stage of the set. Therefore the test objects to be measured should be checked for their voltage conditions before measurement and eventually be made voltageless.

Acoustic monitoring of measured values

Besides the test value reading from the 3½ digit display, the HM8014 unit permits a quality check of the measured value by use of the integrated loudspeaker. The frequency change of the output signal corresponds to the measured resistance value. When the test leads are short-circuited, a frequency of 3-4 kHz is generated. The lowest frequency of 100-200 Hz is generated near the full-deflection value of the measurement range. No signal is heard when open input is used. The volume of the generated signal tone can be controlled with the level selector ⑨. If necessary, the signal can be monitored via the headphones (socket ⑩). During headphones operation, the built-in loudspeaker is switched off.

Notes on two-wire and four-wire measurement

State-of-the-art ohmmeters are generally used to determine the resistance of a test object according to the method shown in figure 1.

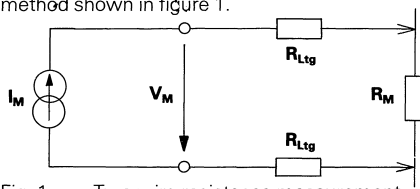

Fig. 1. Two-wire resistance measurement

A constant current of known magnitude is supplied to the unknown R_x resistor. The V_M potential drop across R_M is measured and displayed. This procedure is sufficiently precise, when the leads resistance values of the test leads are small compared to the resistance of the test object. However, when very low resistances are measured, it can no longer be used, because the test probes resistance will lead to inaccurate results. These errors can be avoided by using a procedure known as "four-wire resistance measurement".

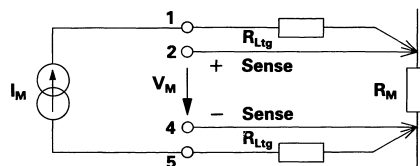

Fig.2. Four-wire resistance measurement

When this type of measurement is used, the test signal has separate current and voltage paths. The test voltage is measured directly at the unknown R_M resistor. The potential drop across the current-carrying test leads is not taken into account. This method is even accurate during measurement of very small resistance values in the $\mu\Omega$ range, but it principally requires connection of 4 test leads for measurement.

HZ17 probe

For this reason, the HM8014 unit is equipped with a special probe (HZ17) including the four-wire measurement system, but requiring connection of only 2 leads to the test object by the user. In both cables, the signal and sense lines are directly combined in the probe tip. The residual resistance of the tip itself can be compensated for by the "Zero calibration" control on the HM8014 front panel, the two probe tips being short-circuited. With this system, a four-wire test lead (Kelvin probe) with only 2 cables is available to the user.

If a "real" four-wire test line is required in special cases, the signal and sense lines can be made separately accessible by cutting off the red and black probe tips of the HZ17 leads and for example soldering them to the test object.

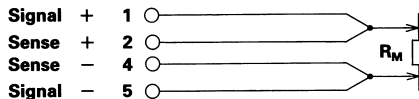

Fig. 3. HZ17 circuitry

Thermoelectric effects

During resistance measurement in the milli- Ω range, a thermoelectric effect must additionally be taken into account, when combining different metals.

The arising problem is caused by the low test voltage used for resistance measurements. In the 200 m Ω range, a test voltage of 4 mV measured at the test object corresponds to 2 μ V/digit. However, voltages of this order already build up due to the thermoelectric effect (thermo EMF), when different kinds of metal are combined. The magnitude of the generated thermoelectric voltage depends on the types of material combined with each other and of their temperature difference. So the combination of soldering tin and copper produces for example several μ V/ $^{\circ}$ C, of copper and Kovar (used for IC pins) several 10 μ V/ $^{\circ}$ C and of copper and copper oxide about 1 mV/ $^{\circ}$ C.

Therefore the following requirements should be met, when low-impedance resistors are measured:

- 1) Test object and probe tips should have the same temperature.
- 2) The test location should not be warmed up by touching with the hand etc.
- 3) When particular test cables are manufactured, attention should be paid to the corresponding material combinations.

Principle of operation

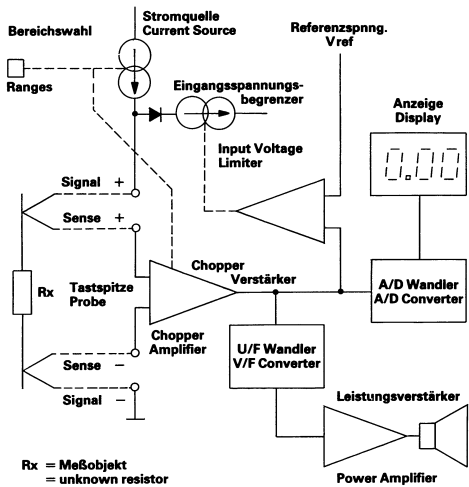

HM8014 block diagram

During resistance measurement with the HM8014 unit, a constant current of precisely known magnitude is routed through the test object. This constant current is supplied by a current source consisting of IC 102 and the T101/102 transistors. The current causes a potential drop across the test object, which is proportional to the resistance value. This voltage is amplified by a low-drift precision amplifier (IC 101) and applied to an A/D converter (IC 201) and a voltage-controlled oscillator (IC 103/ T104). The measured voltage is directly read out as a resistance value from a 3 1/2 digit display.

The VCO consists of a non-linear amplifier (IC 103.1), followed by a variable current source (T104) charging a capacitor (C109) which determines the frequency of the resulting sawtooth signal. It is in proportion to the magnitude of the resistance connected to the input socket. This permits acoustic monitoring of the indicated test value which is made audible by the power amplifier (IC 105) and the loudspeaker.

The high accuracy, even during measurement of very low resistances, is obtained by Kelvin-type measurement. The test object is connected with 4 test leads according to the block diagram. To protect the test object against high voltages and ensure a quick test sequence even in case of large resistance variations, the test voltage is limited to a value of 6 mV or 300 mV according to the measurement range by a voltage limiter (IC 102.2). The limiter measures the voltage at the chopper amplifier output and turns T103 on, as soon as the voltage exceeds a preset threshold value. This permits to control the current supplied by the current source. The constant current and the chopper amplifier gain are switched over corresponding to the measurement ranges in accordance with the following table.

Range	Constant current	IC 101 gain	Max. test voltage	Max. delive. power
200 mΩ 2000 mΩ 20 Ω	20 mA 2 mA 0.2 mA	x50	6 mV	0.12 mW 12 μW 1.2 μW
200 Ω 2000 Ω 20 kΩ	1 mA 0.1 mA 0.01 mA	x1	300 mV	0.3 mW 30 μW 3 μW
▶ 20 mA ▶ 2 mA ▶ 0.2 mA	20 mA 2 mA 0.2 mA	x1	3 V	60 mW 6 mW 0.6 mW

Operational check

General

This test will allow you to check the functions of the HM8014 unit at certain time intervals without using any special test equipment. To obtain the normal operating temperature, the mainframe with inserted module should be switched on at least 60 minutes prior to starting the test.

Measuring equipment required

- 1 Voltage source $1.5V \pm 0.05\%$ or
- 1 DMM HM8011-2 + HM8040 or similar
- 1 Resistor $1\ \Omega \pm 0.05\%$ with 4-wire connection
Precision resistors $0.1\ \Omega \dots 10\ k\Omega \pm 0.05\%$
- 1 Probe for 4-wire measurement HZ17 or similar

Check of the 200 mΩ – 20 Ω ranges

- 1) The measurement is performed directly at the HM8014 input socket without using HZ17.
- 2) Connect the test resistors and compare the reading with the following table.

Range	Reading
200 mΩ	99.6 – 100.4
2000 mΩ	996 – 1004
20 Ω	9.96 – 10.04

Check of the 200 Ω – 20 kΩ ranges

- 1) The measurement is performed directly at the HM8014 input socket without using HZ17.
- 2) Connect the test resistors and compare the readings with the following table.

Range	Reading
200 Ω	99.7 – 100.3
2000 Ω	997 – 1003
20 kΩ	9.97 – 10.03

Diode test function

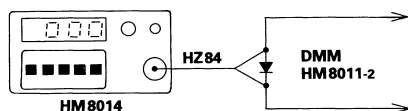

- 1) Connect the diode as shown in the figure.
- 2) Press buttons ⑤ + ⑥ and select a measurement range with buttons ② – ④.
- 3) Check the displayed voltage ① with a multimeter in all 3 measurement ranges.
- 4) The values must be within $\pm(0,25\% + 1\ \text{digit})$

Measuring voltage with open input

- 1) Check voltage between probe tips with DMM.
- 2) Compare the readings with the table in the "Principle of operation" section.

Acoustic test value monitoring

- 1) Select the 2000 Ω range.
- 2) Short-circuit the probe tips.
- 3) Set the desired volume with the level pot. ⑨.
- 4) The generated frequency should be about 3-4 kHz.
- 5) Connect a 1.8 kΩ resistor.
- 6) Now the generated frequency should be about 100-200 Hz.
- 7) No signal tone shall be audible with open input (display overflow).

Calibration

Calibration of diode test function

Setting: ② ⑤ ⑥ ⑨
▶ 2 mA pressed pressed min.

Connect voltage source as follows:

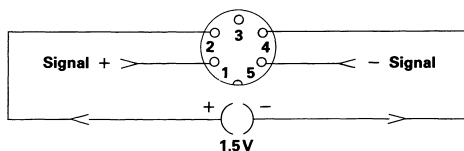

Adjust VR103 until 1500 mV are displayed.

Calibration of the 200 mΩ - 20 Ω ranges

Setting: ③ ⑤
pressed pressed

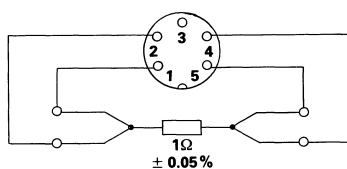

- 1) Connect test resistor as described above.
- 2) Disconnect sense + lead and adjust display to 0000.
- 3) Connect sense + lead to resistor.
- 4) Adjust VR102 until display is 1000 mΩ.

Calibration of the 200 Ω - 20 kΩ ranges

Setting: ② ⑥
pressed pressed

- 1) Connect a resistor of $1\ k\Omega \pm 0.05\%$ to HZ17.
- 2) Adjust VR101 until 1000 Ω are displayed.

HAMEG[®]

Instruments

Oscilloscopes

Multimeters

Counters

Frequency Synthesizers

Generators

R- and LC-Meters

Spectrum Analyzers

Power Supplies

Curve Tracers

Time Standards

Germany

HAMEG Service

Kelsterbacher Str. 15-19
60528 FRANKFURT am Main
Tel. (069) 67805 - 24 -15
Telefax (069) 67805 - 31
E-mail: service@hameg.de

HAMEG GmbH

Industriestraße 6
63533 Mainhausen
Tel. (06182) 8909 - 0
Telefax (06182) 8909 - 30
E-mail: sales@hameg.de

France

HAMEG S.a.r.l

5-9, av. de la République
94800-VILLEJUIF
Tél. (1) 4677 8151
Telefax (1) 4726 3544
E-mail: hamegcom@magic.fr

Spain

HAMEG S.L.

Villarroel 172-174
08036 BARCELONA
Teléf. (93) 4301597
Telefax (93) 321220
E-mail: email@hameg.es

Great Britain

HAMEG LTD

74-78 Collingdon Street
LUTON Bedfordshire LU1 1RX
Phone (01582) 413174
Telefax (01582) 456416
E-mail: sales@hameg.co.uk

United States of America

HAMEG, Inc.

266 East Meadow Avenue
EAST MEADOW, NY 11554
Phone (516) 794 4080
Toll-free (800) 247 1241
Telefax (516) 794 1855
E-mail: hamegny@aol.com

Hongkong

HAMEG LTD

Flat B, 7/F,
Wing Hing Ind. Bldg.,
499 Castle Peak Road,
Lai Chi Kok, Kowloon
Phone (852) 2 793 0218
Telefax (852) 2 763 5236
E-mail: hameghk@netvigatorm.com

44 - 8014 - 0040